

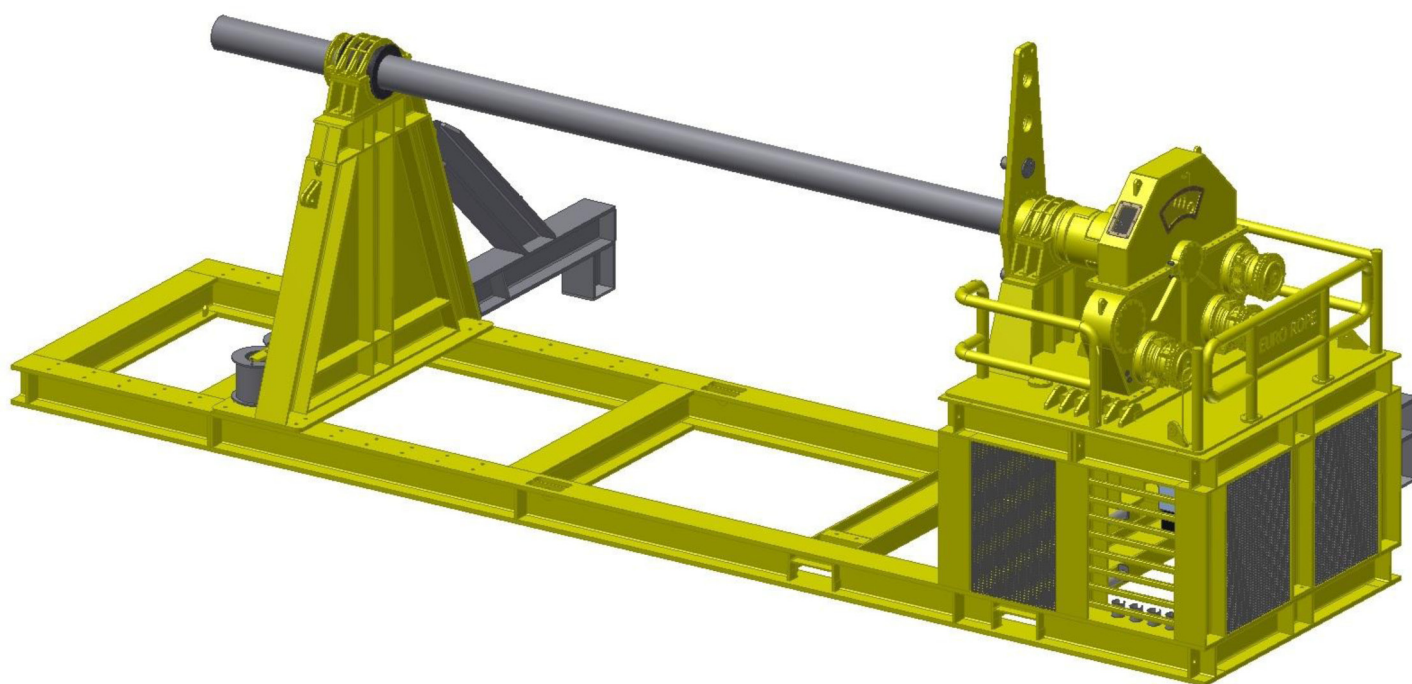

SafeLifting.eu
Your **RENTAL** Partner
Spooler 200T



Technical data

| | |
|---------------------|---|
| Length: | 8372mm |
| Width: | 2840mm |
| Height: | 3419mm |
| Max Reel Dia: | 5000mm |
| Max Reel Width: | 6500mm |
| Machine weight: | 18.500Kg Without shaft |
| Lifting: | Fitted with forklift pockets & 4 point lifting sling set fitted (without reel). |
| Design Temperature: | -10° up to +40°C |
| Guarding: | All moving parts guarded, with the exception of the back and front reel. |

Performance Data

| Layer Diameter (mm) | Pull / Layer (Tonnes) | Winch Speed (M/Min) |
|------------------------|--------------------------|------------------------|
| 500 | 49.75 | 10 |
| 1000 | 24.87 | 20 |
| 1500 | 16.58 | 30 |
| 2000 | 12.44 | 40 |
| 2500 | 9.95 | 50 |
| 3000 | 8.29 | 60 |
| 3500 | 7.11 | 70 |

PLAN VIEW (1:50)

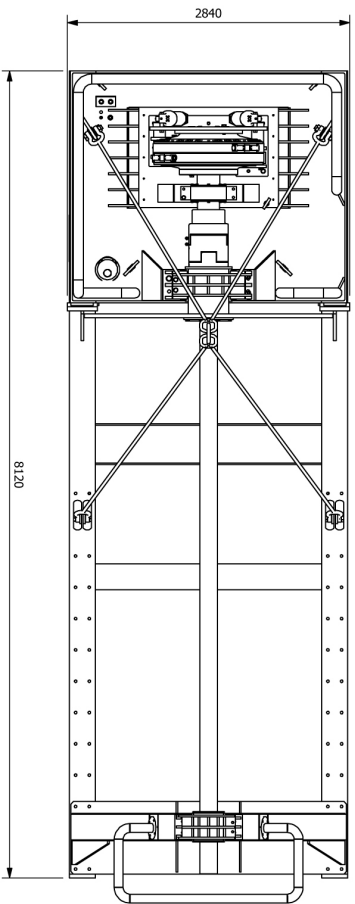

ISOMETRIC VIEW (1:70)

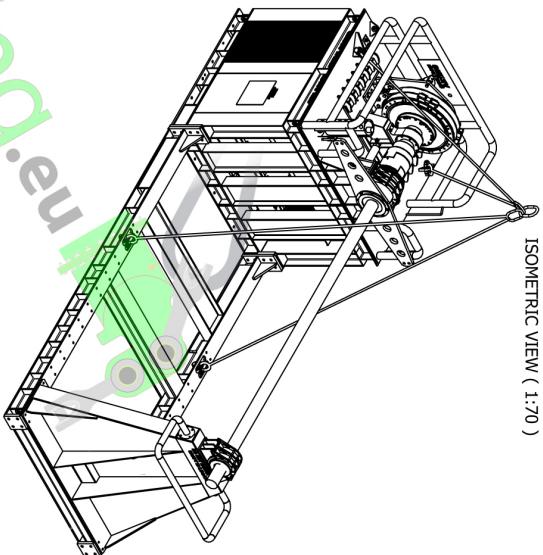

SIDE VIEW (1:50)

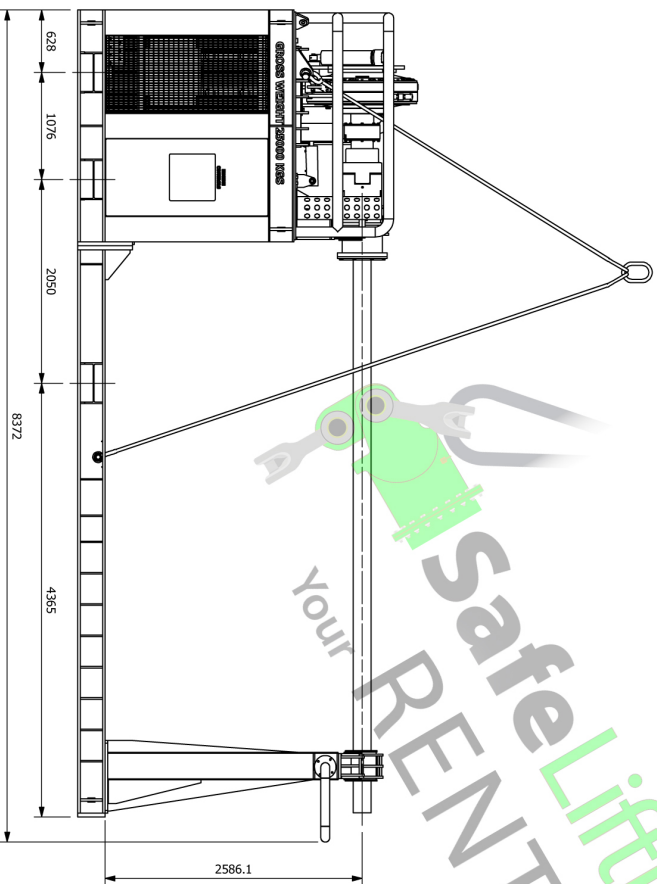

FRONT VIEW (1:50)

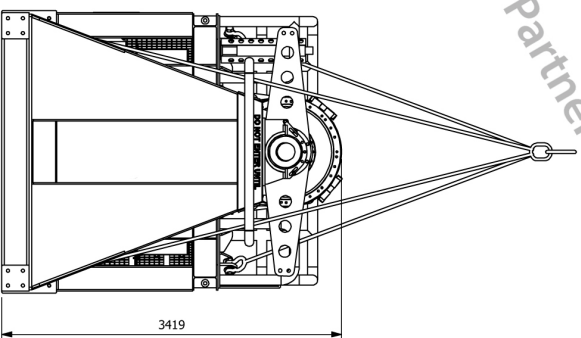

| MATERIALS LIST | |
|----------------|----------------|
| ITEM NO. | DESCRIPTION |
| QTY | MATERIAL GRADE |

- NOTES
1. ALL DIMENSIONS IN MILLIMETRES
 2. ALL DIMENSIONS TO BE IN ACCORDANCE WITH THE DRAWING
 3. ALL WELD SYMBOLS TO CONFORM TO BS590 PART 2 : 1980
 4. ALL BURRS AND SHARP EDGES TO BE REMOVED
 5. ALL BOLTS, NUTS AND WASHERS TO BE IN ACCORDANCE WITH BS5692 GRADE 8.8 UN O.
 6. ALL BOLTS NUTS AND WASHERS TO BE GALVANISED IN ACCORDANCE BS729 : PART 1
 7. ALL PAINTING TO BE IN ACCORDANCE WITH AWS 1.1
 8. ESTIMATED WEIGHT OF ASSEMBLY AS SHOWN : 28800 KGS
 9. LOAD TEST : XXXXXXXXXX
 10. LOAD TEST : 100% MIP PRIOR TO AND AFTER LOAD TEST
 11. NOT REQUIREMENTS

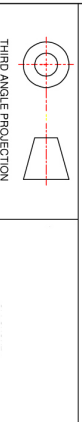

200T MODULAR SPOOLER GA

| | | | |
|-------|-------------|--------|-----|
| SCALE | DRAWING No | SHEET | REV |
| 1:50 | 011-103-008 | 1 OF 1 | B |

GENERAL TOLERANCES
 STEEL FABRICATIONS : ±3.00 MM UNO
 MACHINING : ±0.25 MM UNO
 ANGLE : ±1.05 UNO

MACHINED CORNER RADS
 INSIDE : 0.50 MM UNO
 OUTSIDE : 0.65 MM UNO



| REV | DATE | BY | CHKD | APPD | APPD | APPD | APPD | APPD | APPD | TITLE EDITED | ISSUED FOR INFORMATION | ISSUED FOR COMMENT | COMMENT |
|-----|----------|----|------|------|------|------|------|------|------|--------------|------------------------|--------------------|---------|
| B | 30/01/14 | RM | AR | DA | DA | DA | DA | DA | DA | | | | |
| A | 14/01/14 | AR | DA | DA | DA | DA | DA | DA | DA | | | | |
| 0 | 14/01/14 | AR | DA | DA | DA | DA | DA | DA | DA | | | | |