

User Instructions

TRUN MOD 600X/1000

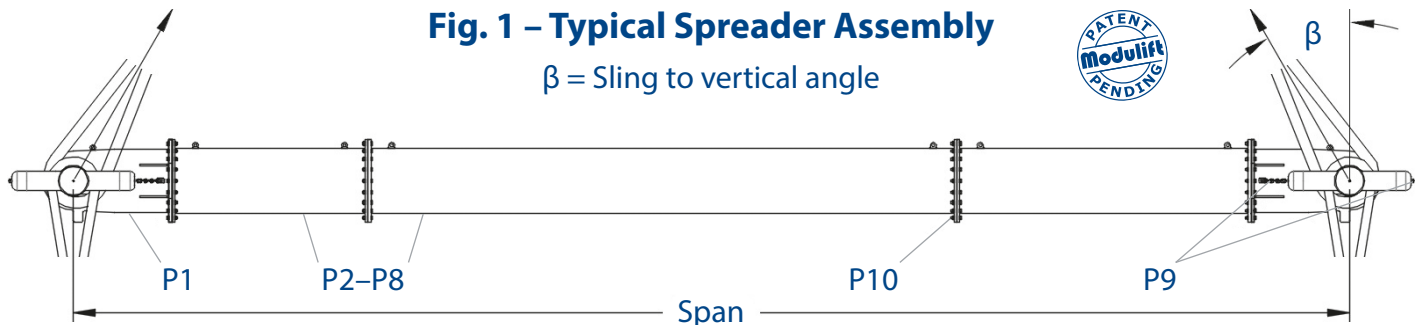

The Modulift Trunnion Spreader is modular in length. Every Trunnion spreader consists of two End Units and intermediate struts that can be bolted into the assembly to achieve different spans. The Trunnion end unit is also compatible with existing Modulift struts. The TRUN MOD 600/1000 has an assembled span ranging from 2 metres to 26 metres in 0.5 metre increments.



TRUN MOD 600/1000 Beam Specification

- Separate top slings must be used to ensure stability of the spreader. Do not loop the top sling through the crane hook. The slings at any one end of the spreader must match each other in length.
- Max. combined sling diameter on one side: 360mm.
- Trunnion dia. 310mm. Please check bending radius (D/d)
- Rated at 1000 tonnes up to 21m (30° STV). See load table for WLL at longer spans.
- STV (sling to vertical) angle β , 45° or less.
- End Units are rated at 500 tonnes WLL each (1000 tonnes combined capacity)
- **Bolt torque: 250Nm.** Spanner size required 36mm.
- Recommended additional equipment: Torque Wrench, Podger Spanner and a Ring Spanner
- Maximum STV Angle of the bottom slings is 45°
- The maximum in plane angle of the bottom slings is 6° STV. If this needs to be exceeded please contact Modulift prior to the lift.
- When specifying slings, use an additional factor of 1.2 to allow for uneven sling lengths. Refer to Modulift if in doubt.

Table 1 – Component List

Part Ref.	Description	Weight/item
P1	Trunnion End Unit	2200kg
P2	6.0m Strut	2665kg
P3	5.0m Strut	2265kg
P4	4.0m Strut	1865kg
P5	3.0m Strut	1470kg
P6	2.0m Strut	1070kg
P7	1.0m Strut	675kg
P8	0.5m Strut	475kg
P9	Sling Retainer Bars	5kg
P10	M24 x 90, Grade 10.9, HT Bolts, Nuts & Washers	



WARNING!

- Personnel using this system should be suitably trained, competent and have a clear understanding of Safe Slings procedures, see Modulift assembly and setup procedure.
- The use of Modulift equipment must be in accordance with the procedures laid down in 'Lifting Operations and Lifting Equipment Regulations 1998' (LOLER).
- **Never exceed stated WLL** – Adhere to WLL in **Table 2** for particular sling angle used.
- **The top sling length is critical to the safe use of the spreader** – Adhere to **Table 2**.
- Do not under any circumstances hang load(s) from the tube or flanges – the spreader is designed for axial compression, not bending.

User Instructions

TRUN MOD 600X/1000



Assembly Procedure

Please refer to separate assembly and setup procedure for more information.

Do's & Don'ts

- Do ensure to load the spreader through the main trunnion pin only. i.e. adhere to **Fig. 1**.
- Do keep the loaded spreader clear of obstacles – any contact could cause beam failure.
- Do ensure correct use of appropriate top slings, do not twist any slings unnecessarily.
- Do not hang any load from the spreader tube or flanges.
- Do not exceed stated WLL for that particular span – adhere to **Table 2**.
- Do not rig the lower slings more than 30 degrees STV.
- When moving or positioning long struts or assemblies use tag lines to control movement.
- Individual components can be heavy and extreme care must be taken if manual handling.

Recommended top sling types:

Textile slings, cable laid wire rope slings or grommets. Slings must have soft eyes. Always ensure clearance between the sling and end unit.

Note: Lengthening the slings can give greater clearance. Refer to Modulift supplier if in doubt.

 **WARNING!**

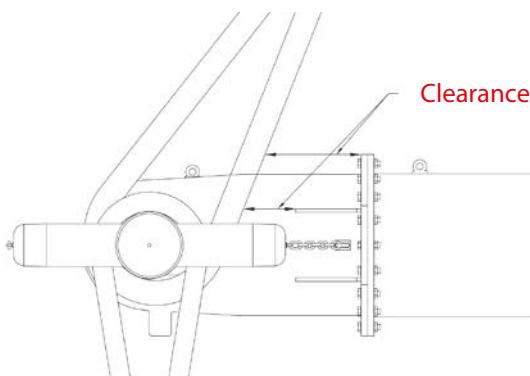

- The rigger must ensure that there is a clearance between the sling end fitting and the end unit as shown above.
- Max number of struts allowed in spreader assembly: 6.
- Assemble longer struts in the centre of the spreader configuration.
- Sling angle is crucial to safe use of spreader.

Table 2 – Load v Span

Span (m)	Sling To Vertical Angle (STV) β		Recommended Configuration							
	WLL (t)	30° Min. top sling length (m)	EU - End Unit (1m)							
2	1000	2	EU	EU						
3	1000	3	EU	1	EU					
4	1000	4	EU	2	EU					
5	1000	5	EU	3	EU					
6	1000	6	EU	3	1	EU				
7	1000	7	EU	3	2	EU				
8	1000	8	EU	6	EU					
9	1000	9	EU	6	1	EU				
10	1000	10	EU	6	2	EU				
11	1000	11	EU	6	3	EU				
12	1000	12	EU	3	6	1	EU			
13	1000	13	EU	3	6	2	EU			
14	1000	14	EU	6	6	EU				
15	1000	15	EU	6	6	1	EU			
16	977	16	EU	6	6	2	EU			
17	899	17	EU	6	6	3	EU			
18	821	18	EU	1	6	6	3	EU		
19	749	19	EU	2	6	6	3	EU		
20	688	20	EU	6	6	6	EU			
21	623	21	EU	6	6	6	1	EU		
22	565	22	EU	6	6	6	2	EU		
23	512	23	EU	6	6	6	3	EU		
24	461	24	EU	1	6	6	6	3	EU	
25	416	25	EU	2	6	6	6	3	EU	
26	373	26	EU	1	2	6	6	6	3	EU

To calculate the WLL at intermediate spans utilising the 0.5m strut, round up the span to the next longest span in Table 2, and use the stated WLL.



Assembly and setup TRUN MOD 600X/1000



1. Firstly lay out the 4 top slings and connect them all to the crane hook.
2. Then slew to one end of the beam and connect a pair of slings, before repeating the process at the other end.
3. Ensure that the sling eyes for the top slings are pushed in tight to the side cheeks of the beam, this will leave room for the bottom sling eyes.
4. Lay out the bottom slings and then lift the spreader and put it down in the middle with a pair of slings each side.
5. The bottom slings which are furthest away from the spreader will need to be pulled across the other pair of slings to help the eyes line up with the trunnion.
6. Do not forget to connect the sling retainer bars on both end units before lifting the beam out of reach.
7. When disassembling the beam, the lower slings should be pulled inwards parallel to the spreader, this will ensure that the eyes can be removed easily.
8. Ensure that the Do's and Don'ts of the user instructions are followed to ensure a safe lift.



1. Manufacturer's Contact Details

Modulift UK Ltd
Cordite House, 4 Holton Point, Holton Heath
Trading Park, Poole, Dorset, BH16 6FL,
Website: www.modulift.com
E-mail: info@modulift.com Tel.: +44 1202 621511

2. Introduction

These supplementary instructions are an original instruction in accordance with section 1.7.4 (Instructions and Annex II Declarations) of the EC Machinery Directive 2006/42/EC, and are to be read in conjunction with Modulift's User Instructions that accompany Generic products, and/or in conjunction with the GA Drawing(s) issued for job-specific custom designs.

3. EC declaration of conformity

With reference to the EC Declaration of Conformity accompanying all new Modulift products, the declaration is also referenced below:

We declare that the CE-marked products described in these supplementary user instructions are in compliance with the essential requirements and fulfil all the relevant provisions of the Directive 2006/42/EC, and as a minimum in conformance with the following harmonized standards / applied technical standards:

- BS EN 13155: 2003+A2:2009
- BS EN 1993-1-1: 2005

The products can be incorporated as part/s of a CE-marked lifting assembly but must in that case not be put into service until the final lifting assembly has been declared in conformity with the provisions of the Directive 2006/42/EC.

Our management system complies with ISO 9001:2015 / ISO 14001: 2015 / ISO 45001: 2018 and is certified by DNV – Business Assurance (Certificate no. 176391-2015-AIMS-GBR-UKAS valid until 1st April 2024)

If the products are modified without approval from Modulift UK Ltd, this declaration becomes invalid, and used at user's own risk.

Poole, 12.05.20



Technical Representative: Sue Spencer

4. Markings

Modulift products have an engraved stainless steel I.D. plate containing key information welded to each component. However, there are some small components that are not physically big enough to have a plate welded to them, therefore the key information is engraved directly onto the component.

In accordance with the directive 2006/42/EC section 1.7.3, all components are marked with:

- CE mark
- Modulift's website address (contact details)
- Product name and/or size/designation
- WLL (note: for products that have varying WLL's depending on the assembled configuration, the WLL is referenced in a table in the specific User Instructions)
- Unique identification serial number
- Year of manufacture
- Self weight of component

Additional marking are permitted, provided that it is applied using low stress punches on the I.D. plates, or applied as labels.

5. Intended use

Modulift products are generally items used for Lifting i.e. lifting accessories. These products must only be used for their intended use, as per the detailed User Instructions / GA Drawing accompanying these products. For example, a Spreader Beam designed for compression forces must never be used as a Lifting Beam which is designed for bending forces. Detailed technical data and intended use can be found on the specific User Instructions / GA Drawings specific to the product.

Temperature rating of Modulift main generic products: rated to -20°C to 60°C. Custom products may differ, to be stated on certificate.

Fatigue: Fatigue failure can occur even if the

WLL has not been exceeded. Scenarios in which the product is subjected to variable load over a prolonged period of time, will carry the risk of inducing fatigue. Consider this when deciding service intervals.

The rating of lifting accessories in European Standards assumes the absence of exceptionally hazardous conditions. Exceptionally hazardous conditions include offshore activities, the lifting of persons and lifting of potentially dangerous loads such as molten metals, corrosive materials or fissile materials. In such cases the degree of hazard should be assessed by a competent person and the working load limit adjusted accordingly.

6. Assembly

Generally, Modulift products are used as part of a lifting rig used in lifting operations. Lifting rigs tend to contain many different types of lifting accessories interconnected.

Modulift are experts in designing and manufacturing modular products, that need assembly prior to use. Follow the User Instructions regarding assembly, paying particular attention to ensuring bolts, nuts & washers are tightened to the required tightening torques.

Additional rigging accessories such as slings are usually either connected directly to the Modulift product, or via connection shackles and other accessories. These additional rigging accessories manufactured by other manufacturers will have their own User Instructions and EC declarations, refer to these specific instructions/declarations and ensure these rigging accessories are properly assembled & used.

7. User instructions

Modulift's products must only be used after reading and understanding the specific User Instruction(s).

8. Lifting: Planning and Operations

It is required by law that any company undertaking a lifting operation must ensure it is planned and carried out according to a safe system of work. Requirements may vary from country to country, but should as a minimum follow the following guidelines:

All lifting operations must be planned by a suitably trained and experienced competent person.

Planning a lifting operation should include:

- Risk Assessment – identifying all hazards and mitigating the risk
- Method Statement – step-by-step guide for onsite personnel to follow
- Determining complexity of lift rating
- Details of qualified personnel to be involved in the lift e.g. slinger/signaller, lift supervisor, riggers
- Detailed force calculations used to determine correct sizing of lifting equipment being used in the rig
- Details of sling lengths to ensure the hook is directly over the CoG
- Sizing of slings to take into account offset CoG as there will be higher forces on the heavy side
- Accuracy of weight and CoG position of the items to be lifted – by calculation or weighing
- Safety factor applied to the weight of the skids being lifted
- Stability calculation: the CoG is above the connection points in the top skid – check for toppling
- Site details, permissible floor loadings, access etc.
- P.P.E. for all personnel
- Name of qualified AP (Appointed Person) that has prepared the lift plan, and their contact details in case of issues

All operators to follow safe sling procedures and to be suitably trained and experienced, competent persons. Operators must check equipment WLL for the specific configurations against the plan / rig drawing.

A competent person must check the rig prior to commencing the lift. The path of the load that it will be maneuvered through must be checked for obstacles. The safety of other persons not involved in the lift must be considered. Any deviations to the planned lift must be discussed and agreed with the person responsible planning the lift.

Modulift UK Ltd are not responsible for planning the lift and are not liable in any way for the advice stated above.

9. Inspection prior to each use

The manufacturer's EC Declarations of conformity certificate must be found to be in order for all equipment, and that the Modulift product(s) is/are precisely as ordered.

Before each use the Modulift product(s) must be inspected for obvious damage or deterioration.

The inspection should be done in accordance with local regulations. If there is any doubt with regards to these criteria being met, the product(s) must not be used for a lifting operation. Modulift are able to provide inspection guidance if required.

10. General instructions for safe use

General comments for lifting rigs:

- Do not exceed the stated WLL of the Modulift product at the required configuration (see UI)
- - Do not exceed the WLL of the specific connection point on the product, consider the position of the CoG of the load being lifted
- - Top sling STV for spreaders must not be greater than 45 degrees / greater than the specified STV – top sling length is crucial.
- - Check the stability of the rig design – if the CoG of the load is above its connection points – see example opposite:
- Ensure that the rig is designed so that the CoG of the item being lifted is directly below the hook point, otherwise the rig will tilt and could overload lifting equipment.
- - Ensure the load being lifted is strong enough to be lifted in the proposed method.
- - All equipment within the rig must be of a suitable capacity.
- - The rig should be checked by a competent person prior to commencing lifting to ensure it is correct as per the rig drawing, and everything is securely fastened.

B > A = Stable

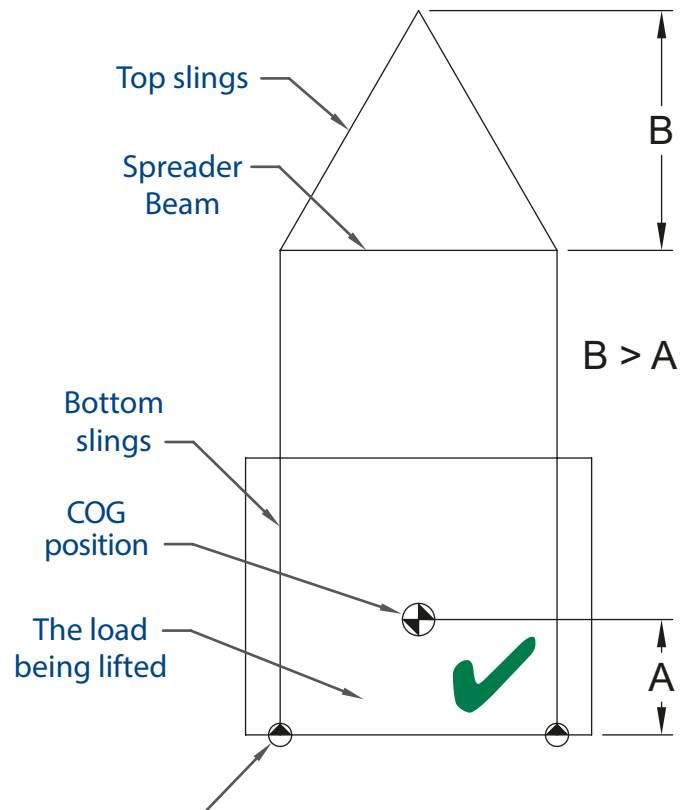

Connection point

B < A = Unstable

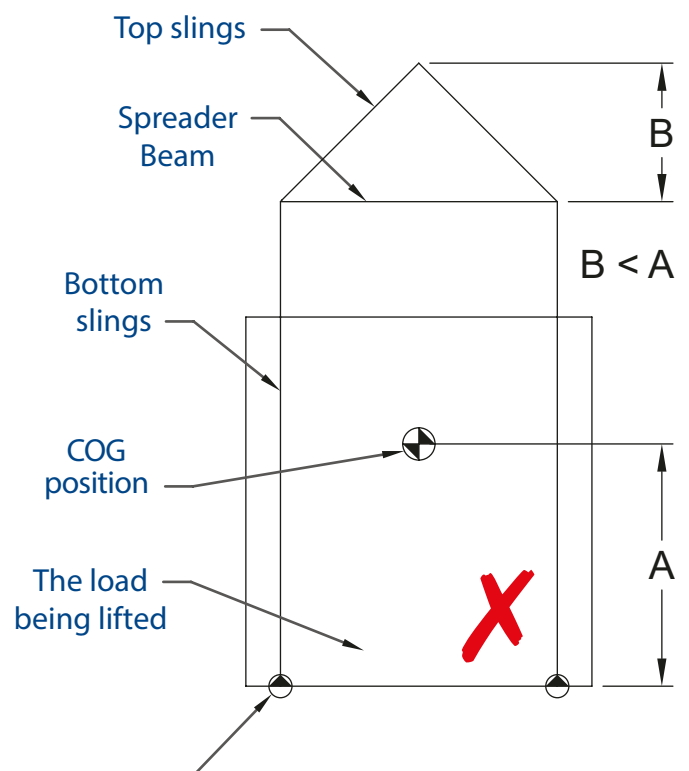

Connection point

11. Thorough examination

A thorough examination should be carried out by a competent person at intervals not exceeding six months, and at sooner intervals in accordance with local laws or where the equipment is used in extreme environments.

Components that have cracks, are visibly distorted or twisted, severely corroded, or have gouges in excess of 10% of the thickness of the material should be discarded and replaced, or repaired. The thorough examination should be carried out by a competent inspector.

Fasteners should be inspected prior to each use, and discarded if any visible damage to the bolt shank or the thread.

12. Repair

Repairs must be done by Modulift if possible, but in exceptional circumstances repairs can be done by a third party in strict accordance with Modulift's requirements & express approval.

It is essential that Modulift is contacted to discuss any repairs before proceeding, otherwise the Modulift declaration becomes invalid.

13. End of life

Modulift products are generally made from structural mild steel that can be widely recycled.