

Material : Alloy steel  
 Safety factor : 5 times  
 Standards : Generally according to US Federal Spec RR-C-271  
 Finish : Painted  
 Temperature range : -40°F up to +392°F, Polar Rated  
 Standard certification : Certificate of Conformity  
 3.1 material certificate EN 10204

Non-standard sizes or custom products available on request

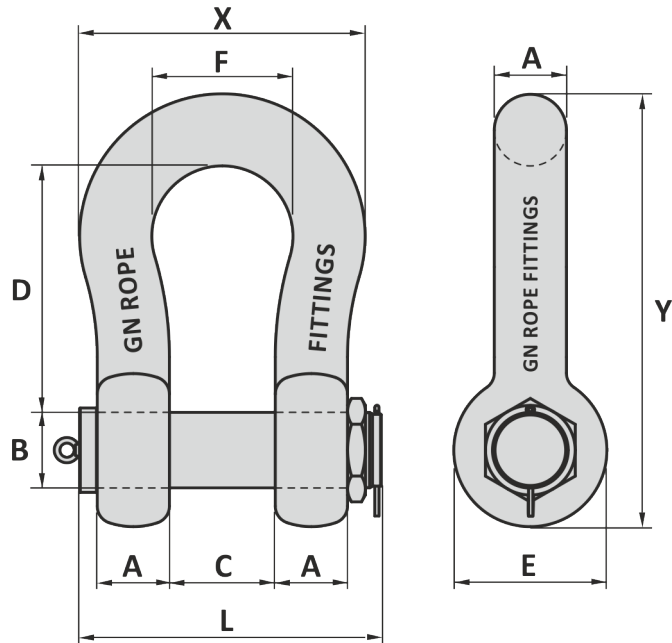
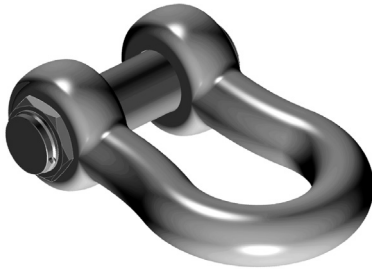

\* Shackles from WLL 1250 ton completed with eyebolts on both sides

Art. No.	WLL ton	A inch	B inch	C inch	D inch	E inch	F inch	L inch	X inch	Y inch	Weight lbs
37001209	120	3 1/2	3 3/4	5 29/32	14 31/32	7 7/8	9 3/8	16 17/32	16 3/8	24 9/32	243
37001509	150	4	4 1/4	6 11/16	15 3/4	9 1/16	10 13/16	18 11/16	18 7/8	26 13/32	353
37002009	200	4 23/32	4 15/16	7 3/32	19 11/16	10 1/4	11 13/32	20 15/32	20 7/8	32	518
37002509	250	4 15/16	5 1/2	8 1/16	21 1/4	10 1/4	12	22 1/16	21 27/32	34 1/16	628
37003009	300	5 1/8	5 23/32	8 1/16	23 5/8	12	12	22 7/16	22 1/4	37 23/32	750
37004009	400	6 1/2	6 7/8	9 1/16	26 25/32	13 25/32	12 13/16	26 3/16	25 25/32	43 3/8	1312
37005009	500	7 3/32	7 7/32	10 1/32	27 7/16	14 7/16	13 25/32	28 11/32	27 15/16	45 19/32	1510
37006009	600	7 11/16	8 1/16	11 1/32	27 7/16	15 15/16	14 3/4	32 3/32	30 7/8	47 1/4	1940
37007009	700	8 1/16	8 9/16	12 3/16	27 7/16	17 1/8	15 3/4	33 7/8	31 7/8	48 15/32	2161
37008009	800	8 1/4	8 9/16	12 3/16	27 7/16	17 1/8	15 3/4	34 1/4	32 9/32	48 21/32	2425
37009009	900	8 21/32	9 1/16	13	27 7/16	18 5/16	16 17/32	35 13/16	33 7/8	49 15/16	2822
37010009	1000	9 1/16	9 7/16	13 25/32	29 1/32	18 29/32	16 17/32	37 13/32	34 21/32	50 25/32	3219
37012509	1250	10 15/16	10 3/8	14 7/16	30 23/32	23 3/32	17 23/32	43 1/2	39 3/4	58 21/32	5115
37015009	1500	11 1/32	11 13/32	14 7/16	31 1/2	24	17 23/32	43 1/2	39 3/4	60 1/4	5401
37017509	1750	11 13/16	13	16 15/16	37 1/32	26	21 1/4	48 7/16	44 7/8	68 11/16	7231
37020009	2000	12 19/32	14 3/16	18 1/8	41 1/32	26 25/32	22 1/16	51 3/16	47 1/4	74 13/32	8642

Tolerance: Inside length ± 7.5%, all other forged parts ± 5%, machined parts ± 1/32 inch

29-06-2021

Material : Alloy steel  
 Safety factor : 5 times  
 Standards : Generally according to US Federal Spec RR-C-271  
 Finish : Painted  
 Temperature range : -40°C up to +200°C, Polar Rated  
 Standard certification : Certificate of Conformity  
 3.1 material certificate EN 10204

Non-standard sizes or custom products available on request

GENERAL

SHACKLES

THIMBLES

SOCKETS

LINKS

SWIVELS

HOOKS

MOORING

OTHERS

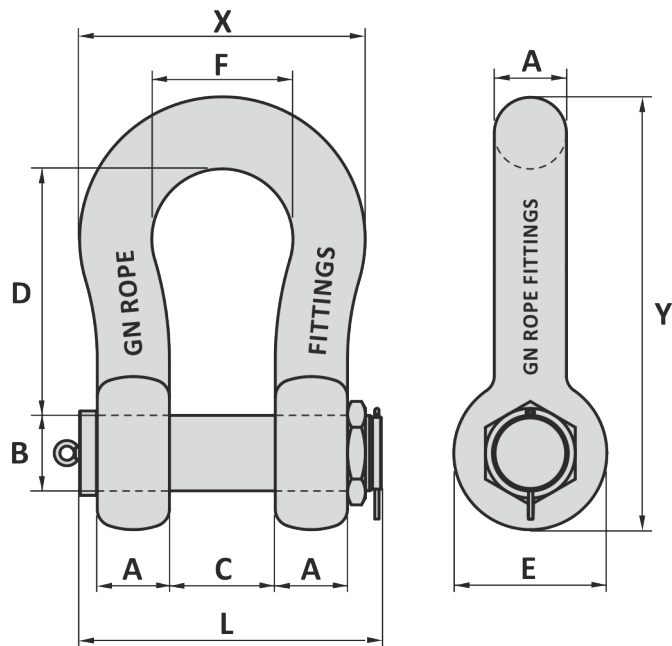
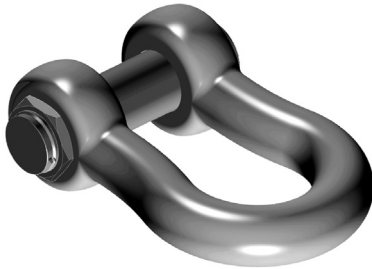

\* Shackles from WLL 1250 ton completed with eyebolts on both sides

Art. No.	WLL ton	A mm	B mm	C mm	D mm	E mm	F mm	L mm	X mm	Y mm	Weight kg
37001209	120	89	95	150	380	200	238	420	416	617	110
37001509	150	102	108	170	400	230	275	475	479	671	160
37002009	200	120	125	180	500	260	290	520	530	813	235
37002509	250	125	140	205	540	260	305	560	555	865	285
37003009	300	130	150	205	600	305	305	570	565	958	340
37004009	400	165	175	230	680	350	325	665	655	1108	595
37005009	500	180	185	255	700	370	350	720	710	1158	685
37006009	600	195	205	285	700	405	375	815	765	1200	880
37007009	700	205	217	310	700	435	400	860	810	1231	980
37008009	800	210	217	310	700	435	400	870	820	1236	1100
37009009	900	220	230	330	700	465	420	910	860	1268	1280
37010009	1000	230	240	350	750	480	420	950	880	1290	1460
37012509	1250	278	270	370	780	590	450	1105	1010	1490	2320
37015009	1500	280	290	370	800	610	450	1105	1010	1530	2450
37017509	1750	300	330	430	950	660	540	1230	1140	1745	3280
37020009	2000	320	360	460	1050	680	560	1300	1200	1890	3920

Tolerance: Inside length ± 7.5%, all other forged parts ± 5%, machined parts ± 1 mm

29-06-2021